

PUREZZA™

PREMIUM WATER

P1 Fonte 65 / 120 / 180

Efficient, high flow and high capacity water dispensing solution for the HORECA sector.

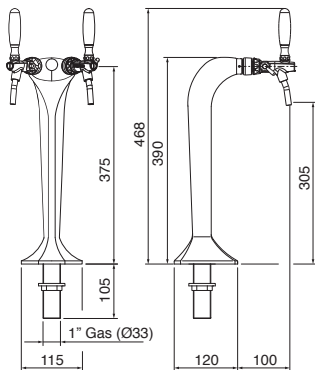

*Dimensions are in mm

*3-way dispensing tap also available

Robust and reliable units catering to all your water requirements

The P1 Fonte under-the-counter range is ideal for the HORECA environment. The versatile range offers three models with different output capacities to suit the needs of any venue.

Ideal for optimising space, these units are compact and sturdy and can fit into almost any venue. Cutting-edge technology allows for high capacity dispensing of still and sparkling water.

Leading technology

The P1 Fonte features two core technologies:



Performance filtration

Professional grade filters and purifiers are fitted to improve taste and reduce odours resulting in great-tasting, crystal-clear water.



Ice Bank cooling system

Ice Bank cooling technology is a necessity in busy HORECA environments where large quantities of consistently ice-cold water are required.

Professional water dispensing solutions for commercial environments

The P1 Fonte range is the recommended solution for HORECA environments such as bars, restaurants, cafes and conference centres.

Features

Clean design with external surfaces in stainless steel to facilitate easy cleaning.

Three water dispensing options – cold, ambient and sparkling.

The products are completed by our range of ergonomic taps.

Superior cooling capacity and fast replenish times.



Model	65	120	180
Dispensing capacity	65 L (~17 gal)/h	120 L (~31 gal)/h	180 L (~47 gal)/h
Water options			
Dispensing operation	Manual Mechanical Taps	Manual Mechanical Taps	Manual Mechanical Taps
Weight	37 kg/ ~81.5 lbs	46 kg/ ~101.4 lbs	52 kg/ ~114.7 lbs
Dimensions	35 cm/13.78” (W) 42 cm/16.53” (D) 50 cm/19.68” (H)	35 cm/13.78” (W) 48 cm/18.90” (D) 50 cm/19.68” (H)	35 cm/13.78” (W) 53 cm/20.87” (D) 50 cm/19.68” (H)
Water temperature	3°- 10°C/38°- 50°F	3°- 10°C/38°- 50°F	3°- 10°C/38°- 50°F

Tested and certified



Waterlogic International Limited reserves the right, in order to reflect continuous research and development, to amend or change specifications without prior notice.

Contact the Purezza team today

Purezza Australia

1300 88 14 14

sales@purezza.com.au

For more information, visit www.purezza.com.au

PUREZZA™

PREMIUM WATER